

STEEL CASE FOR MORTISE DEADLOCK



SPECIFICATION
SHEET

151

- Steel case for high security mortise deadlock
- Designed to make mortise locks easy to fit to gates, simply weld mild steel case into the gate frame.
- Lock case is made from 2.5mm steel.

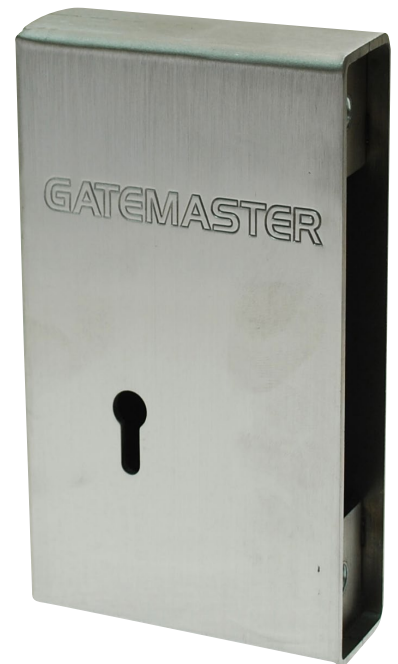

PRODUCT CODE

5CDC

INSTALLATION

Weld the lockcase to the gate and galvanise or paint as part of the gate. Fit the lock into the lockcase and secure with screws.

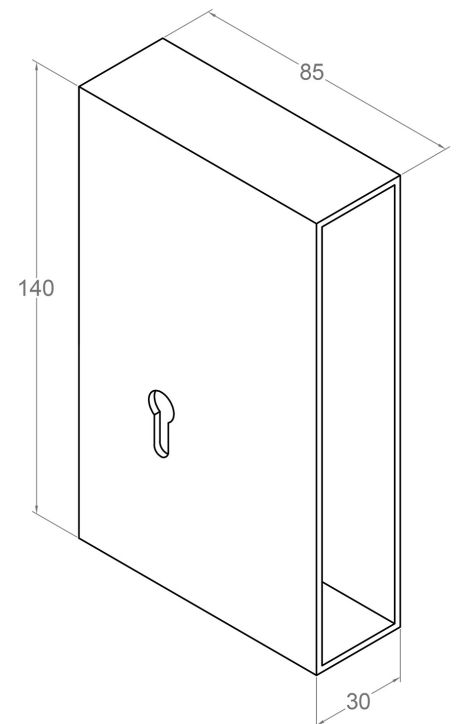

 **GATEMASTER**

VISIT GATEMASTERLOCKS.COM FOR MORE
INFORMATION